

UHF HIGH DENSITY CABINET

S-UHF-LITECAB-101

UHF manually operated single door cabinet

USER MANUAL

Rev. 3.0



Table of contents

1	Installation.....	3
1.1	Physical installation.....	3
1.2	Power supply and Ethernet connection.....	3
1.3	Guide rails	4
1.4	Clearance.....	4
2	Operating instructions.....	5
3	Default EPC data format and Ethernet socket	7
3.1	Ethernet configuration.....	7
4	Software configurations	8
4.1	Graphical User Interface	8
5	Safety and maintenance.....	9
6	Troubleshooting	10
7	Technical specifications.....	11
8	Warranty	12
9	Declaration of conformity	13

1 Installation

1.1 Physical installation

The LiteCab shall be installed on an even floor, with no irregularities, in order to guarantee a stable and safe operation. It provides a levelling system (only little irregularities can be compensated) which is adjusted while installing the cabin.

1.2 Power supply and Ethernet connection

A standard IEC320-C14 main power socket and RJ45 Ethernet connector are located on top of the cabin.

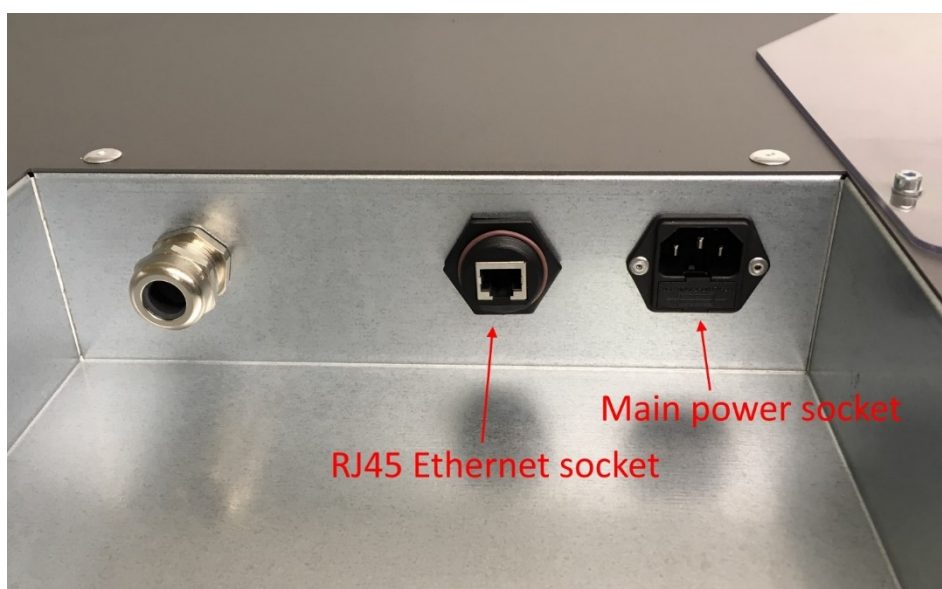

Figure 1- Main power supply and Ethernet sockets

1.3 Guide rails

Inside the LiteCab there are two guide rails to protect the inside walls from accidental collisions with the trolleys. The guide rails can be removed (taking off ten hex nut screws) in case a pallet or a wide trolley shall be loaded into the cabin. Additional care must be taken while operating the cabin without guide rails.

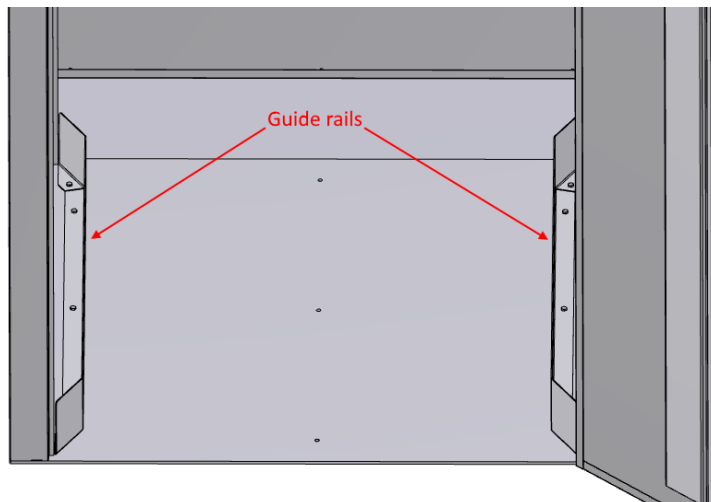

Figure 2- Guide rails.

1.4 Clearance

The sides of the cabin are fully shielded and clearance is not required around the LiteCab. However, no tagged items should be placed in front of the LiteCab door while it is reading. Even though the slots around the door are narrow, they could potentially lead to some unwanted readings.

2 Operating instructions

The main power switch, located inside the LiteCab allows to turn on and off the main power.



Figure 3- Main power switch.

Once turned on, the software system which manages the LiteCab takes about one minute to boot up. While starting the illuminated push button on the cabin will turn on both in green and red for a few seconds. This behaviour is considered as normal.

The illuminated push button turns green when the LiteCab is ready to operate, the door is closed and secured with the door knob.

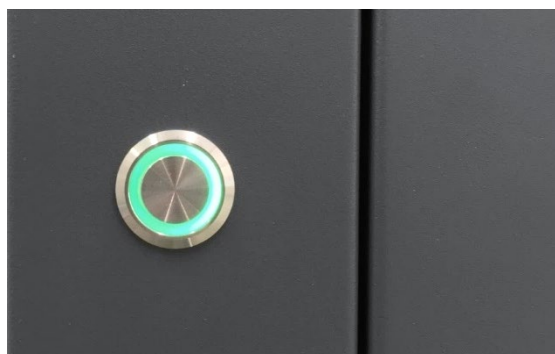

Figure 4- Push button.



Figure 5- Door switch.

A reading cycle can be started only if the push button is green illuminated (this means the LiteCab is ready and the door is closed). When the push button is pressed, it turns red and the reading starts. When the reading ends, the light turns green and the door can be opened.

By default, the reading time is automatically adapted to the amount of tags which are inside the LiteCab and it lasts at least one second. A fixed reading time can be set if required.

The reading cycle is immediately stopped if the door is opened while it is ongoing. In this case the collected EPCs are incomplete and they shall be discarded.

If the door is open the push button is not illuminated.

The following table summarizes the status of the illuminated push button.

Illuminated push button	LiteCab status
Not illuminated	The door is open or the LiteCab is not powered up
Green	The door is closed and the LiteCab is ready
Red	A reading cycle is ongoing
Red and green	The LiteCab software system is booting up

Table 1 – Illuminated push button status.

3 Default EPC data format and Ethernet socket

The default data format is a 96 bits EPC followed by LF CR (Line Feed Carriage Return) characters.

The EPCs are sent over a RAW Ethernet socket on port 14150.

It is possible to customize the EPC data format and the Ethernet socket port number through the web based graphical user interface.

3.1 Ethernet configuration

The LiteCab Ethernet interface is configured in DHCP mode by default. In addition, an hostname is preconfigured. The default hostname is: speedwayr-xx-xx-xx where xx-xx-xx are the last six digits of the MAC address. The MAC address is printed on a label attached inside the LiteCab.

The network interface of the LiteCab can be configured directly through the web based GUI. For more info see paragraph 4.1.

4 Software configurations

The LiteCab comes with a standard software setup which allows to operate it without requiring any special configuration after the installation. It is powered by Datamars' Cloudburst software.

The default software configuration should provide a very high reading accuracy in most of the use cases. However, the RFID parameters and EPC data format can be customized through a web graphical user interface.

4.1 Graphical User Interface

To access the LiteCab graphical user interface make sure it is powered on, ready and connected through the Ethernet port to the same network of the PC used for the configuration.

Type `https://` followed by the IP address of the reader or its host name (e.g. `https://192.168.1.110` or `https://speedwayr-11-4b-73.local`) in your favorite web browser (e.g. Mozilla Firefox) address bar and press enter.

Depending on the browser privacy settings, a security warning may show up. It is totally safe to proceed and accept the security exception.

You will be prompted for a login operation. Default password is: password.

For additional information about Cloudburst and the description of the parameters, please refer to the user manual available at the following link: <https://www.textile-id.com/cloudburst/>.

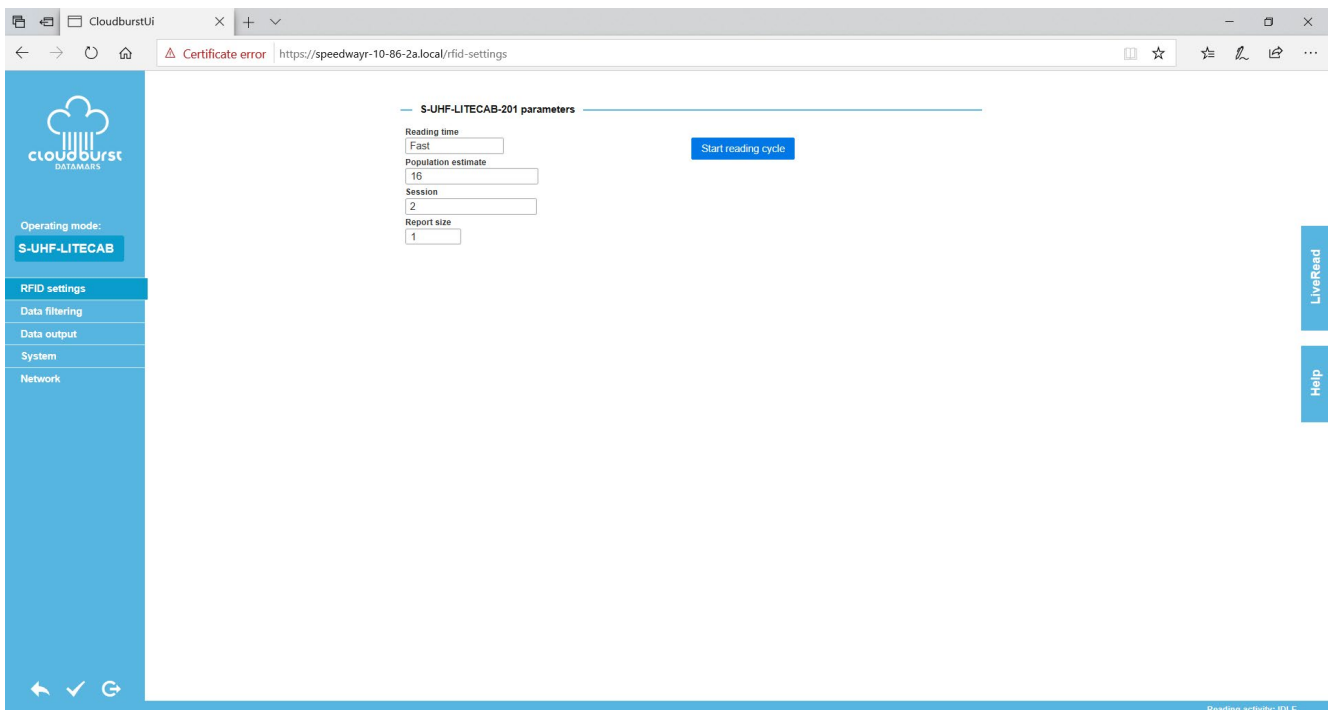

Figure 6- Cloudburst Graphical User Interface.

5 Safety and maintenance

Please read this paragraph carefully in order to ensure that a correct care and maintenance plan is followed to guarantee optimal operation of the LiteCab.

- Storage
 - Do not expose the LiteCab to water or moisture.
- Cleaning
 - Gently wipe outer and inner parts with a soft damp cloth and dry them immediately.
 - Do not use high pressure water jet to clean the LiteCab; the product is not waterproof.
- Handling and operation
 - Handle and operate the LiteCab with care; significant shocks may damage it.
 - Be sure not to hit the door switch when loading the cabin and do not apply excessive force on it. Damage may occur resulting in incorrect operation and failure detecting the door position.
 - Do not operate the LiteCab while people are inside it.
 - Do not place any load on top of the LiteCab.
- Maintenance
 - Keep the door switch clean. Periodically check its proper operation manually pressing it while checking the status of the illuminated push button according to Table 1.
 - Periodically check that the hinges are properly working and the screws are tightened.
 - Do not remove the plastic panels inside the LiteCab. Risk of electric shock may exist if panels are removed by non-authorized personnel.
 - Do not attempt any modification to mechanical and/or electrical parts of the cabin. If extraordinary maintenance is required, please contact Datamars Textile ID support at support-tid@datamars.com. Unauthorized service will void the warranty.

6 Troubleshooting

If any problem arises while using the LiteCab, the following table should help to find out a solution.

If the problem persists or is not listed, please contact Datamars Textile ID support at support-tid@datamars.com or call landline support at: +41 (0)91 935 73 80.

Symptom	Cause and solution
The push button illumination is off	<ul style="list-style-type: none"> - If the door is open, close and secure it with the door knob. - The LiteCab is not powered up. Check the main power cable and the main power switch. - The door switch fails in sensing the door. Carefully operate the door switch by hand, if the push button turns green the switch and/or the door require maintenance. Please contact Datamars support. - The software is not properly configured or a general failure occurred. Turn off the LiteCab, wait 10 seconds and turn it on again. If the problem persists, please contact Datamars support.
No EPC codes are sent over the Ethernet interface	<ul style="list-style-type: none"> - Check the Ethernet connection. - Run subsequent reading cycles of the same items is not possible. Once an RFID tag is identified by the LiteCab a persistence time must be observed before read it again. The persistence time is not a LiteCab parameter, it is RFID tag dependent and it could last more than 60 seconds. However, it is usually not required to identify the RFID tags twice. - The software is not properly configured or a general failure occurred. Turn off the LiteCab, wait 10 seconds and turn it on again. If the problem persists, please contact Datamars support.
The graphical user interface is not reachable	<ul style="list-style-type: none"> - Check the Ethernet connection. - Check that the LiteCab address and port number typed in the web browser' address bar are correct. - The software is not properly configured or a general failure occurred. Turn off the LiteCab, wait 10 seconds and turn it on again. If the problem persists, please contact Datamars support.

7 Technical specifications

External dimensions (L x W x H)	1170 x 1090 x 2286 mm (46" x 43" x 90") S version 1170 x 1390 x 2286 mm (46" x 43" x 90") L version
Maximum internal dimensions (L x W x H)	1000 x 1042 x 2061 mm (39" x 41" x 81") S version 1000 x 1342 x 2061 mm (39" x 41" x 81") L version
Weight	Approx. 220 kg (485 lb) S version Approx. 245 kg (551 lb) L version
RFID compliances	ISO/IEC 18000-6C EPC Class 1 Gen 2 ETSI EN 302 208 (865 – 868 MHz)
Interface	RJ-45 connector, 10/100 Mbps Ethernet interface
Operating voltage range	Single phase 100 – 240 V AC, 50 – 60 Hz
Maximum operating current	1,4 A
Operating temperature	-20°C to +50°C (-4°F to +122°F), non-condensing

8 Warranty

Datamars S-UHF-LITECAB-101 follows standard warranty rules for Datamars reading systems and it is guaranteed for one year from the delivery date.

9 Declaration of conformity

The customer's electrical system, where the LiteCab is connected to, must be equipped with an RCD (Residual Current Device) in order to guarantee the fully compliance with the regulations stated in the declaration of conformity.

  DECLARATION OF CONFORMITY	
Manufacturer name:	Datamars SA
Manufacturer address:	Via ai Prati CH, 6930 Bedano
DECLARES, under its own responsibility, that the product S-UHF-LITECAB	
is in accordance with the following standards:	
<ul style="list-style-type: none">• EN 60204-1:2006 Safety of machinery<ul style="list-style-type: none">- Electrical equipment of machines- Part 1: General requirements• EN 302 208 2 V2.1.1• EN 301 489-1 V1.9.2• EN 301 489-3 V1.4.1	
Electromagnetic compatibility (EMC) and Radio spectrum Matters (ERM)	
and satisfies the essential requirements of the following directives:	
<ul style="list-style-type: none">• Machinery Directive 2006/42/EC• EMC Directive 2004/108/EC and EMC Directive 2014/30/EU• Radio equipment and Telecommunications Terminal Equipment 1999/5/EC	
Date: 22-06-2017	 Signature: Pachoud Damien Chief Technology Officer
<small>Datamars SA Via ai Prati - CH-6930 Bedano-Lugano - Switzerland - Phone +41 91 935 73 80 - Fax +41 91 945 03 30 www.datamars.com</small>	